



## Modular ice maker - Pebble system Daily production up to 410 kg

Hotel	████████████████████
Restaurant	████████████████████
Fast food	████████████████████
Bar	████████████████████
Disco	████████████████████
Fish market	████████████████████
Supermarket	████████████████████
Medical & SPA	████████████████████
Industry	████████████████████

### ► Position n°



### ► Features & Plus

- Pebble ice - 91% dry
- 1l (water) - 1kg (ice) - only Air cooled
- AISI 304 SS Scotch Brite finish
- Tropical class +43°C
- Specific volume 1 m<sup>3</sup> = 550 kg of ice
- Removable and cleanable air filter
- AISI 304 SS evaporator
- Air or water cooling system
- Easy cleanable internal rounded surfaces
- Dust-proof water basin
- RoHS Free
- Electromechanical operation
- ON-OFF rocker switch
- Automatic water charge
- Rotation sensor on low speed shaft
- Standard and special voltages
- Frame in INOX
- HFC Free



### ► Usable Bins

- Bin 240PE
- Bin 110
- Bin 200
- Bin 350
- Bin 550V DS
- Roller Bin 100
- Double Roller Bin 100
- Double Roller Bin 500
- Double Roller Bin 1200



Removable and cleanable air filter



AISI 304 SS evaporator



Dust-proof water basin



Rotation sensor on low speed shaft



Frame in INOX

### ► Available pebble size

drawing for reference only

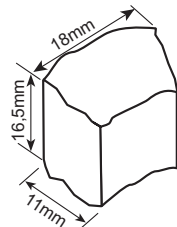

### ► Prod. 24h

Air temp.	Water temp.		Kg	Lbs	
	10° C	50° F			7° C
10° C	50° F	7° C	45° F	410	904
21° C	70° F	15° C	60° F	350	772

**2 Years Warranty**  
subject to limitations

### ► Certifications available for this model





Ice Pebbles

# TM 450 HC



## Modular ice maker - Pebble system Daily production up to 410 kg

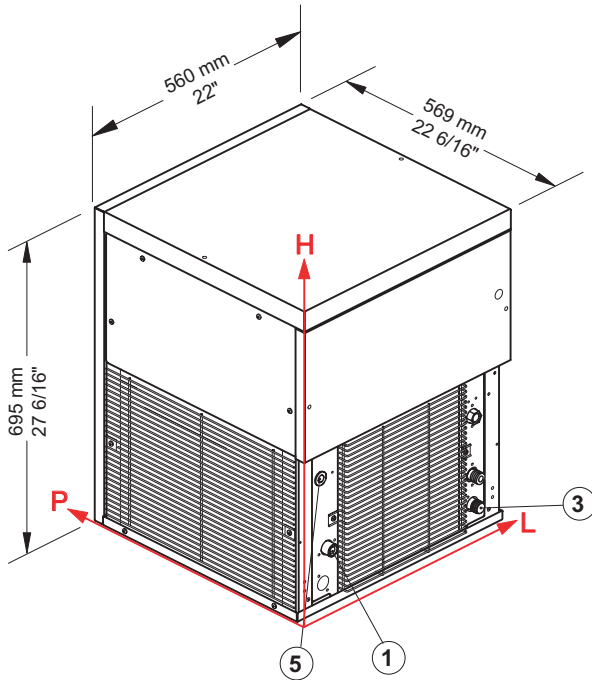

### ► Working conditions

- Location: **Indoor**

	Min	Max
Ambient temperature	+10° C / +50° F	+43° C / 110° F
Water temperature	+3° C / +37° F	+32° C / +90° F
Voltage	-10%	+10%
Water inlet pressure	1bar (14 psi)	6bar (84 psi)

### ► Performances

	Air temperature	Water temperature					
		7° C	45° F	15° C	60° F	21° C	70° F
	10° C	410 kg					
	50° F		976 lbs				
	21° C			350 kg			
	70° F				772 lbs		
	32° C					284 kg	
	90° F						626 lbs

### ► Connections

All measures are referred to the down-left corner (L-H-Ø)

- ① Water in.: 85,5 mm / 3 6/16" - 130 mm / 5 2/16" - 3/4"
- ③ Water out.: 479,5 mm / 18 14/16" - 65 mm / 2 9/16" - 24 mm / 15/16"
- ⑤ Electrical connections: 67,5 mm / 2 11/16" - 290 mm / 11 7/16"

### ► Technical information

Production in 24h	350 kg / 772 lbs	Water consumption	A: 1 l/kg - 12,0 gal/100 lbs
Cooling system	A	Sizes (L-P-H mm)	560 - 569 - 695
Approximate pebble size	16,5 x 18 x 11	(L-P-H in)	22 - 22 6/16 - 27 6/16
Refrigerant	R290	Sizes with pack (L-P-H mm)	645 - 645 - 910
Standard voltage	220-240 V ~ 50 Hz	(L-P-H in)	25 6/16 - 25 6/16 - 35 13/16
Average power consumption	1415 W	Net weight	102 kg / 225 lbs
Fuse	16 A	Gross weight	113 kg / 249 lbs
Electrical consumption	11 kWh/100kg	Finish	AISI 304 stainless steel, scotch brite

All the technical information need to be considered at the following conditions:

- Ambient temperature +21° C
- Water temperature +15° C
- Electrical consumption at +32° C (standard voltage)
- Average power consumption at +43° C (standard voltage)

Models and specifications are subject to change without notice

Rev. 00 - Issued April 2018



[www.bremaice.it](http://www.bremaice.it)  
info@bremaice.it

Bim + Data  
download

