



Self-contained ice maker - Pebble system
Daily production up to 150 kg

Hotel	████████████████████
Restaurant	████████████████████
Fast food	████████████████████
Bar	████████████████████
Disco	████████████████████
Fish market	████████████████████
Supermarket	████████████████████
Medical & SPA	████████████████████
Industry	████████████████████

► Position n°



► Features & Plus

- Pebble ice - 91% dry
- 1l (water) - 1kg (ice) - only Air cooled
- AISI 304 SS Scotch Brite finish
- Tropical class +43°C
- Adjustable Stainless Steel feet
- Removable and cleanable air filter
- AISI 304 SS evaporator
- Air or water cooling system
- Easy cleanable internal rounded surfaces
- HCFC-Free insulated storage
- Dust-proof water basin
- RoHS Free
- Disappearing insulated door
- Electromechanical operation
- ON-OFF rocker switch
- Automatic water charge
- Standard and special voltages



AISI 304 SS Scotch Brite finish



Removable and cleanable air filter



AISI 304 SS evaporator



Dust-proof water basin



Disappearing insulated door

► Available pebble size

drawing for reference only

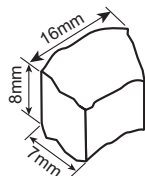

► Prod. 24h

Air temp.	Water temp.		kg	lbs
	10° C	50° F		
10° C	50° F	7° C	150	331
21° C	70° F	15° C	140	309

2 Years Warranty
subject to limitations

► Certifications available for this model





Ice Pebbles

TB 1404



Self-contained ice maker - Pebble system Daily production up to 150 kg

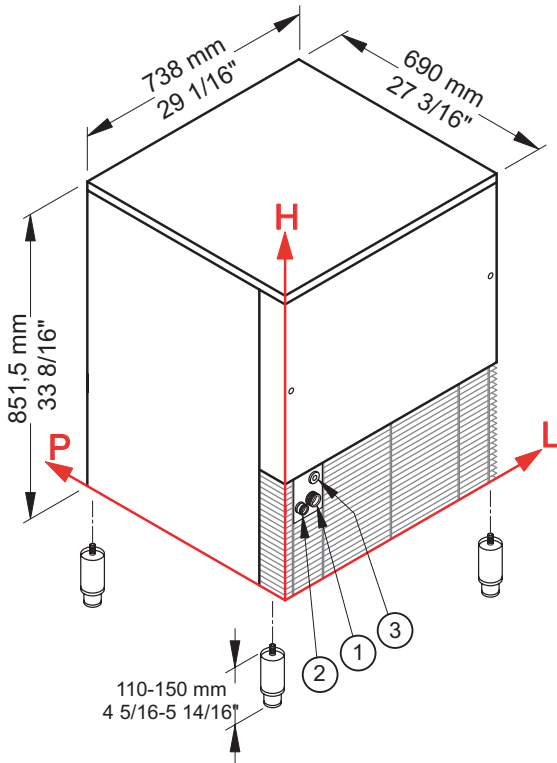

► Working conditions

- Location: **Indoor**

	Min	Max
Ambient temperature	+10° C / +50° F	+43° C / 110° F
Water temperature	+3° C / +37° F	+32° C / +90° F
Voltage	-10%	+10%
Water inlet pressure	1bar (14 psi)	6bar (84 psi)

► Performances

	Air temperature	Water temperature					
		7° C	45° F	15° C	60° F	21° C	70° F
	10° C	150 kg					
	50° F		331 lbs				
	21° C			140 kg			
	70° F				309 lbs		
	32° C					126 kg	
	90° F						278 lbs

► Connections

All measures are referred to the rear bottom-left corner (L-H-Ø)

- ① Water in.: 104 mm / 4 2/16" - 182 mm / 7 3/16" - 3/4" Ø
- ② Water out.: 53 mm / 2 1/16" - 175 mm / 6 14/16" - 24 mm / 15/16" Ø
- ③ Electrical connections: 92 mm / 3 10/16" - 254 mm / 10"

► Technical information

Production in 24h	140 kg / 309 lbs	Water consumption	A: 1 l/kg - 12,0 gal/100 lbs
Store capacity, up to	40 kg / 88 lbs		W: 6,4 l/kg - 76,7 gal/100 lbs
Cooling system	A - W	Sizes (L-P-H mm)	738 - 690 - 851,5
Approximate pebble size	8 x 16 x 7	(L-P-H in)	29 1/16 - 27 3/16 - 33 8/16
Refrigerant	R452A	Sizes with pack (L-P-H mm)	780 - 735 - 1015
Standard voltage	220-240 V ~ 50 Hz	(L-P-H in)	30 11/16 - 28 15/16 - 39 15/16
Average power consumption	650 W	Net weight	90 kg / 198 lbs
Fuse	10 A	Gross weight	100 kg / 220 lbs
Finish	AISI 304 stainless steel, scotch brite		

All the technical information must be considered at the following conditions:
 Sizes without feet
 Ambient temperature +21° C
 Water temperature +15° C
 Average power consumption at +43° C (standard voltage)
 Refrigerant R404A

Models and specifications are subject to change without notice

Rev. 03 - Issued May 2018



www.bremaice.it
info@bremaice.it

Bim + Data
 download

